

alma

PRESENTATION DE NOS SOLUTIONS DE MANUTENTION



Portique de levage



Portique déplaçable



Mono rail de guidage



Potence murale



Potence sur pieds

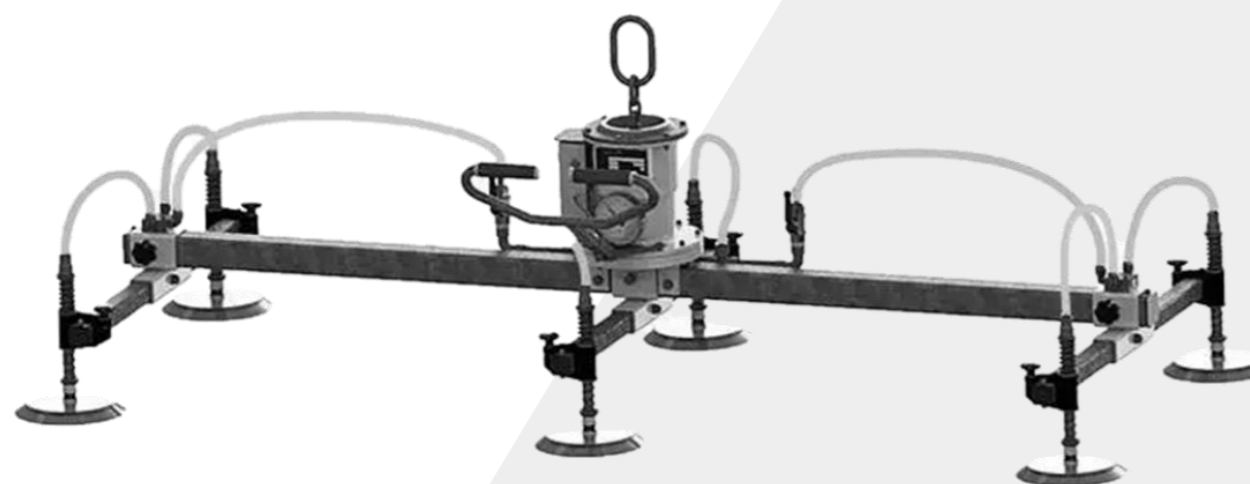

Préhension mécanique

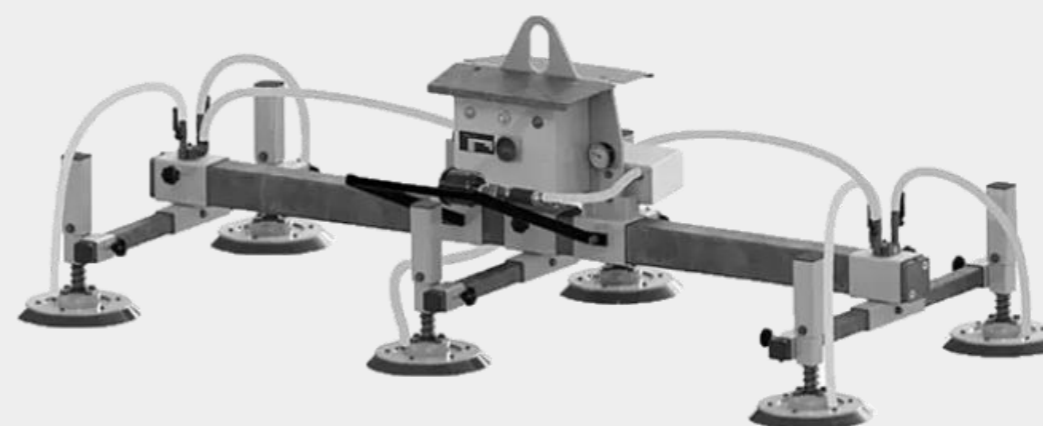

Préhension électrique

Potence sur fût :

Rotation 270° ou 360°

Charriot manuel ou électrique

Palan manuel ou électrique

Charge 125kg / 250kg / 500kg, etc.



Potence sur fût triangulée
(économique)



Potence sur fût inversée
(avec gain de hauteur)



Potence sur fût articulée
(plus d'aisance de mouvement)

Potence murale :

Rotation 180°

Charriot manuel ou électrique

Palan manuel ou électrique

Charge 125kg / 250kg / 500kg, etc.



Potence murale triangulée
(économique)



Potence murale inversée
(avec gain de hauteur)

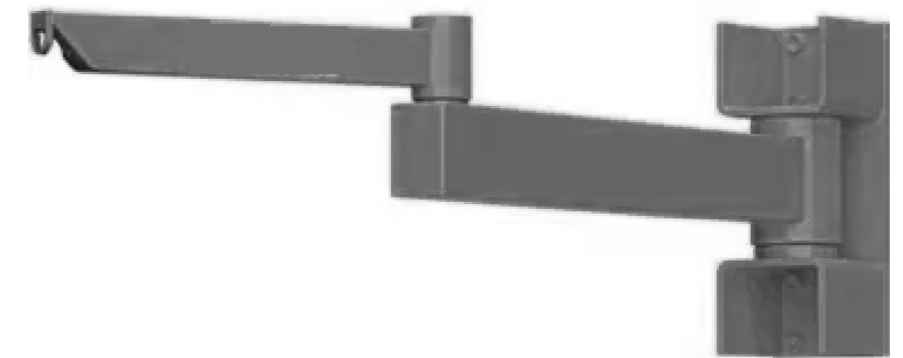

Potence murale articulée
(plus d'aisance de mouvement)

Préhenseur de tôles :

alma

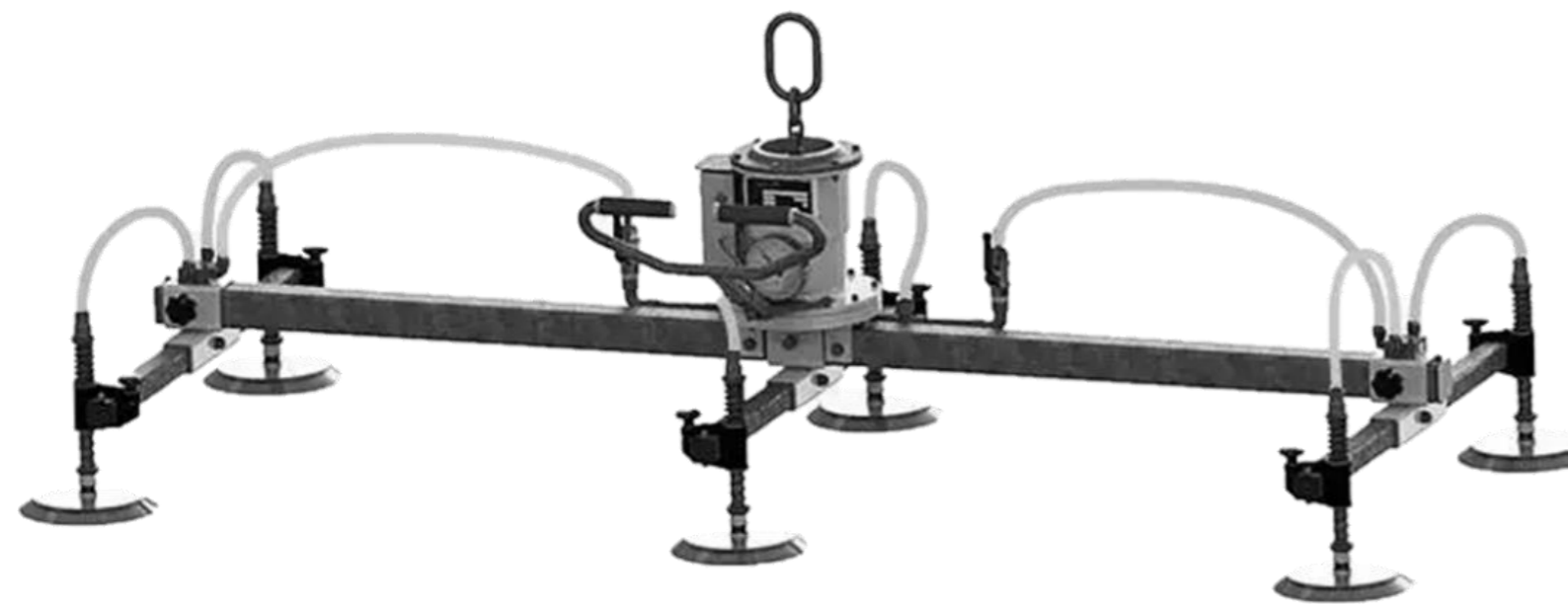

Préhension mécanique

Dimensions : 2000 x 1000

Charge maxi : 270kg

Aucune alimentation



Préhension électrique

Dimensions : 2000 x 1000

Charge maxi : 1250kg

Alimentation en 230V

Projets sur mesures :

alma



Portique de levage



Mono rail de guidage

VUE D'ENSEMBLE DE LA GAMME **alma'**

Pour le cisailage, le pliage :



Pour le roulage,



Pour le sciage :



Pour le cintrage :



Pour la découpe laser :

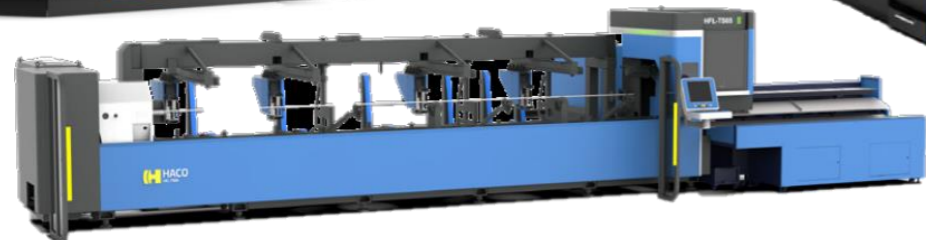
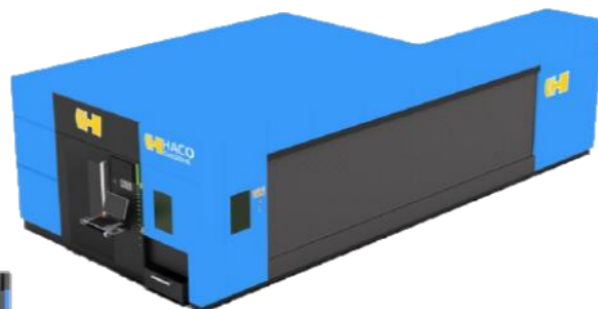
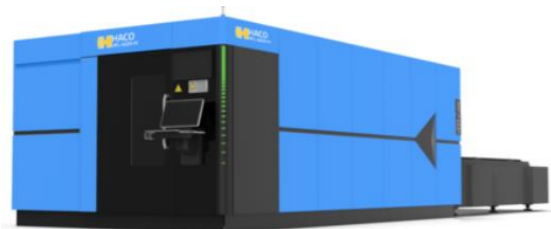

Pour le poinçonnage manuel :



Pour le perçage :



Pour la découpe plasma :



SPALECK
INDUSTRIES



Pour la découpe jet d'eau :



Pour le poinçonnage automatique, l'encoçage

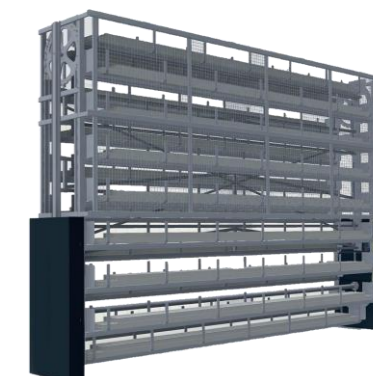
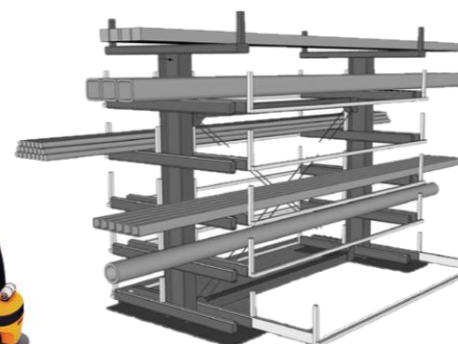

alma

alma, pour faire le bon choix
la proximité, la qualité, la sérénité.

alma rayonne sur le Sud-Est



COORDONNEES

06 03 31 56 88

jean-baptiste@alma-machines-outils.fr

<http://alma-machines-outils.fr/>